



61W10SV-PM (Panel Mounted) Panel PC

Product range for harsh environments

A user friendly MMI system for Communication and Control System



Rugged Design

- Touch Input Device (TID)
- Multi Function Terminal
- Monitoring
- Supervision
- Communication Terminal Device
- Air Traffic Management
- Defense
- Automation and Control

Characteristics

The MILCOTS 61W10SV Panel mounted Smart Panel PC Series offers a range of adaptable features

- High display quality (SVGA or XGA)
- CPU “scalable” performance (ETX technology)
- Easy integration (waterproof mounting version)

The relevant choice of standard technologies allows MILCOTS to provide long life commitment for these products

Key Points

- High quality display (brightness, contrast and viewing angles)
- Fanless
- Dimming
- IP 54 front face
- Compact size, easy integration
- Linux and Windows XP supported
- Long term support (10 to 15 years program requirements)
- RoHS compliance

Options

- Alternate CPU
- RAM and storage

61W10SV- PM (Panel Mounted) Panel PC

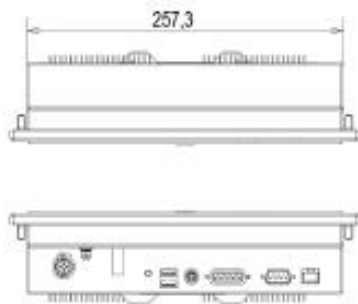
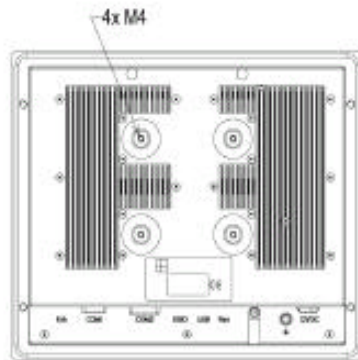
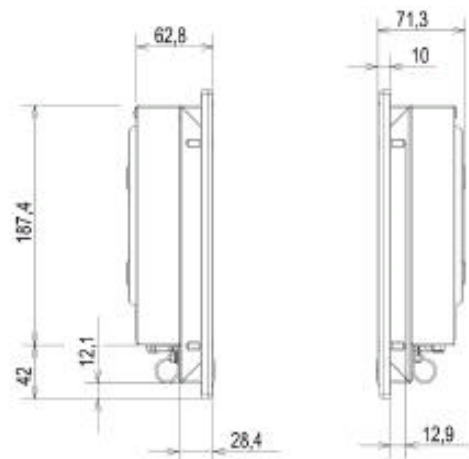
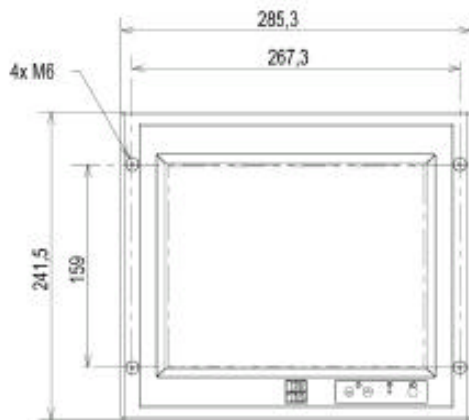

Display Module
 Size: 10"4
 Addressability: 800 x 600 (SVGA)
 Brightness: 400 cd / m²
 Contrast ratio: 700 : 1
 Dot pitch: 0,264 mm
 Viewing angles: 170° / 170°
 Display colors: 262 144
 Active display area: 211,2 x 158,4 mm

Touch screen characteristics Resistive 6 wires

Integrated computer
 Architecture: ETX Form Factor
 Microprocessor: Pentium M 1.1 GHz
 Memory: 256 Mo to 1 Go of DDR-SDRAM
 Serial Ports: 2 RS232, RS 232/485
 USB: 2 USB 2.0
 Ethernet: 1 Ethernet 10/100 Base T
 Keyboard/ Mouse: 1 PS/2 (keyboard/mouse)
 Disk: Flash disk 256 Mo to 64 Go or rotational 2" disk
 Operating system: Windows XP, Windows XP Embedded or Linux

Physical Features
 Dimensions: 11.23" (W) x 9.5" (H) x 2.8" (D)
 Weight: 7.5 lbs
 Standard Color: Powder Black
 Waterproofness: IP 54 front face
 Packaging: Aluminum
 Fastners: 4 x M6 screws for waterproof mounting

Environmental Conditions
 Operating Temperature: 0°C to +50°C
 Storage Temperature: -20°C to +65°C
 Humidity: 20% to 90%
 Shock: 15G / 11 ms
 Vibration: 0,67G RMS (10 to 500 Hz)

Electrical features and certifications
 Power Consumption: 30 W
 RoHs Compliance
 Input Voltage and certification:

61W10SV-PM-XX	CE EN 60950	MIL STD 461
24 VDC input on circular connector external power supply non delivered	-4A	-4D
24 VDC input of circular connector external power supply 24 VDC 115/230V 50/60 Hz	-1A	-
115/230V 50/60 Hz in IEC 320 connector	-2A	-

Warranty 1 year (3 to 5 years optional)

